

How to assemble and use

EZ RECORD MAKER

Estimated assemble time: about 60 minutes
 ※ You can see the assemble video on 大人の科学 .net(otonanokagaku.net)

What is included

※ The turntable is balanced to rotate smoothly, so be careful not to apply extra force

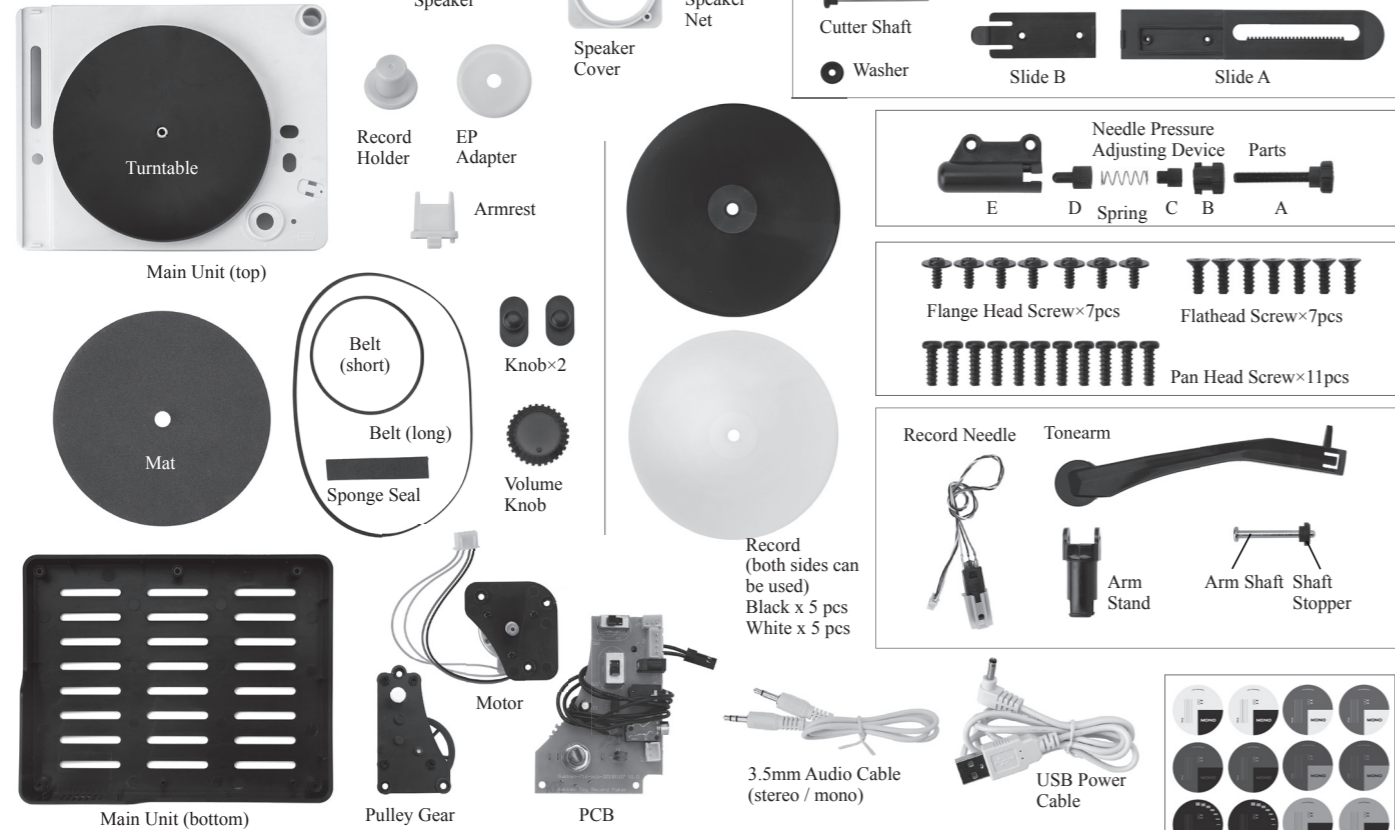

Things to prepare

Plus screwdriver, power supply with USB port (such as mobile battery, USB-AC adapter), sound source device with earphone jack (such as a smartphone or a PC), headphone jack adapter (one for iPhone), cutter, ruler, glue.

Caution while setting the screw:

When driving the screw, make sure the screwdriver is seated properly on the screw head. Apply even pressure while setting the screw. As the screw is design to etch the plastic, so if you try to use too much force in setting the screw, it may break. The advisable power balance is a downforce of 7 to the turn force of 3.

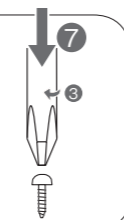

⚠ <Warning> Be sure to observe the following to avoid fire or electric shock.

- If metal, water, or foreign matter gets inside the product while product is operating, disconnect the USB cable from the Main Unit.
- If smoke, unusual odor, unusual noise, drop, or damage occurs, disconnect the USB cable from the Main Unit.
- Do not use the USB terminal or power terminal if it is not completely inserted.
- Do not use the USB terminal or power terminal with dust attached, and do not bring any metal objects close to the terminal.

⚠ <Caution> For your own safety, please carefully read the instructions and precautions in this manual before experimenting.

- There is a risk of suffocation, so beware of the small part, such as screws around small children.
- Beware of the sably, Modifications, or any use other than the intended use listed in this kit, is strictly prohibited, and is to be done at your own risk.
- Do not use if the Main Unit or the parts are damaged or deformed.
- Do not spill liquids on the unit, or operate the unit if the unit is wet.
- Operating power is 5V 1.0A. Please use the USB-AC adapter for this operating power.
- After use, disconnect the USB cable from the Main Unit. Do not move the unit while the cable is connected.
- Please use and keep the unit on a flat and stable surface.
- Do not use or store the unit in places exposed to oil slicks or steam, or in places with high levels of moisture or dust.
- When pulling the Cord to connect/disconnect the USB terminal or power supply terminal, be sure to hold the connector firmly. Also, do not insert or remove cables with wet hands.
- When cleaning, be sure to remove the USB cable from the Main Unit.
- Keep out of reach of small children at all times.



[Name of each part]

While recording, the cutting needle will cut the groove in the record. You can use both sides of the record for recording.

The sounds are made during playback, when the Record Needle, which is at the tip of the Tonearm, tracks the groove of the records.

Recording / Playback Switch
 Recording Switch ◦
 Playback Switch ▷

Rotation Speed Switch
 33 → 33 1/3 revolutions per minute
 45 → 45 revolutions per minute

Power Terminal
 Dedicated USB power terminal for USB power cable.

Input Terminal (IN)
 Connect a sound source device, music, or sound you want to record. Connect the cable to this dedicated 3.5mm audio terminal.

Output Terminal (OUT)
 You can connect an external speaker or earphone to the unit as an option.

Volume Switch
 Power ON/OFF and sound input/output volume change.

LED
 LED lights up when the power is on.

Labels in diagram: Cutter Head, Cutting Needle, Tonearm, Record Needle, Record, Slide, Built-in Speaker, Turntable.

Assemble the Main Unit

1 Paste the Mat on the Turntable.

Align the hole of the Mat to the axis of the Turntable. Peel off a small portion of the Protection Film and then paste the edge at the correct position. Afterwards, peel off the rest to paste the Mat entirely.

⚠ The Mat can not be peeled off once it is pasted. Handle with care when pasting.

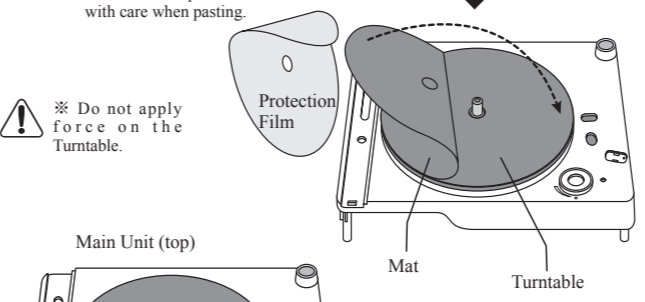

2 Hang the Belt (long).

Turn the Main Unit (top) upside down. Hang the Belt (long) around the Turntable and the protrusion.

⚠ Do not apply force on the Turntable.

Make sure the belt is not twisted.

Hang onto the side of the larger disc.

The belt is hung onto this protrusion

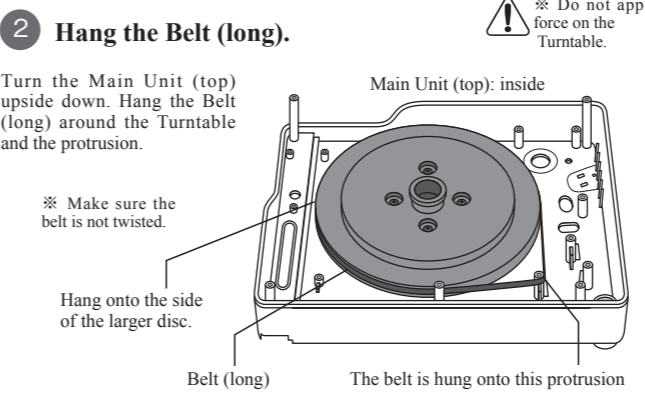

3 Attach the Arm Stand and the Armrest.

Put the Arm Stand and the Armrest into the holes on the Main Unit (top). Press the tip of the Arm Stand and push it in until it clicks. The Armrest has 2 claws and 1 protrusion on the bottom, insert accordingly into the hole.

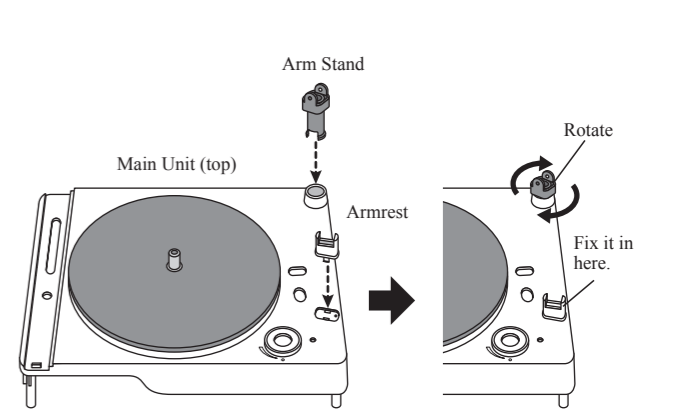

4 Make the Slide.

Align Slide A and Slide B with the two screw holes. Fasten with Flathead Screws.

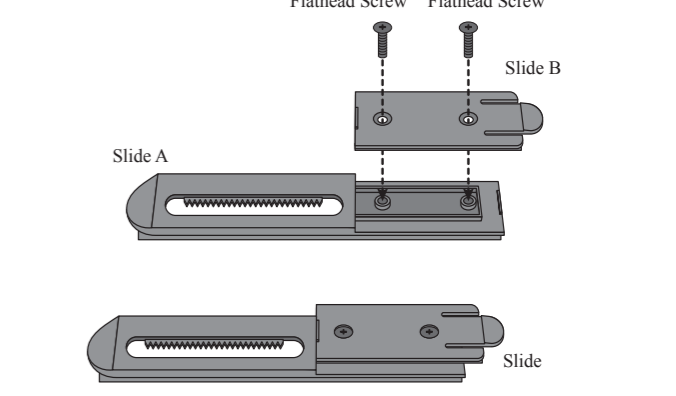

5 Attach the Slide.

Insert the Slide into the groove at the end of the Main Unit (top) and then fasten it with a Flange Head Screw through the Washer from inside.

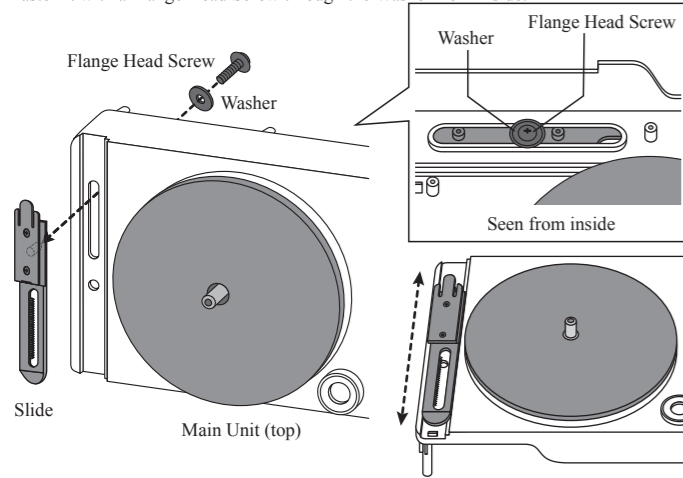

※ Move the Slide and make sure that it moves smoothly.
If the movement is not smooth, try loosening the Flange Head Screw slightly.

6 Install the Pulley Gear and the Motor.

Align the Pulley Gear to the 3 screw holes at the upper left inside the Main Unit (top) and then fasten it with the Flathead Screws.

Next, place the Motor on the lower right in accordance with the 3 screw holes and then fasten it with the Pan Head Screws.

When attaching the Motor, re-attach the Belt (long) that was previously hung on the protrusion of the Main Unit to the axis of the Motor.

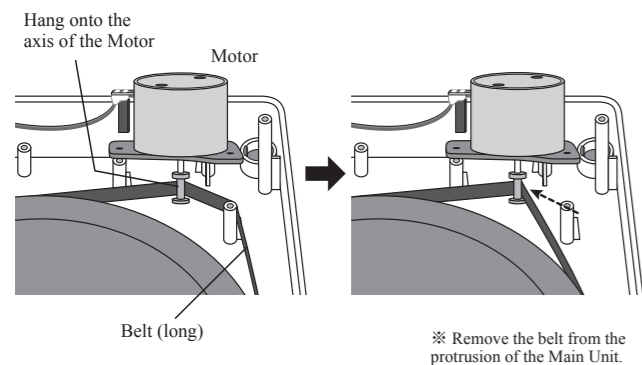
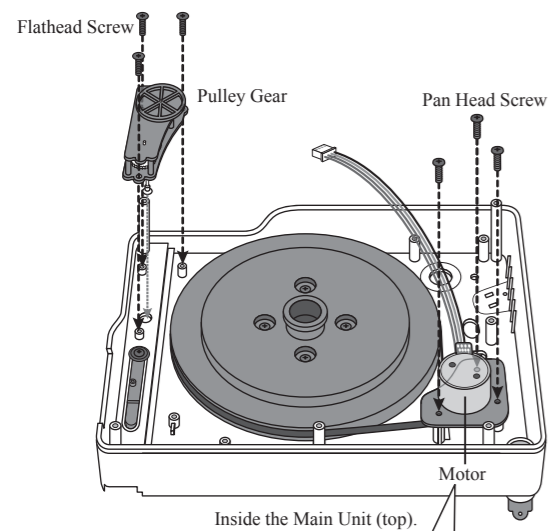

※ Remove the belt from the protrusion of the Main Unit.

7 Assemble the Speaker.

Insert the Speaker Net into the Speaker Cover. Then, insert the Net Holder from above. Finally, attach the Speaker and then fasten it with the two Flange Head Screws.

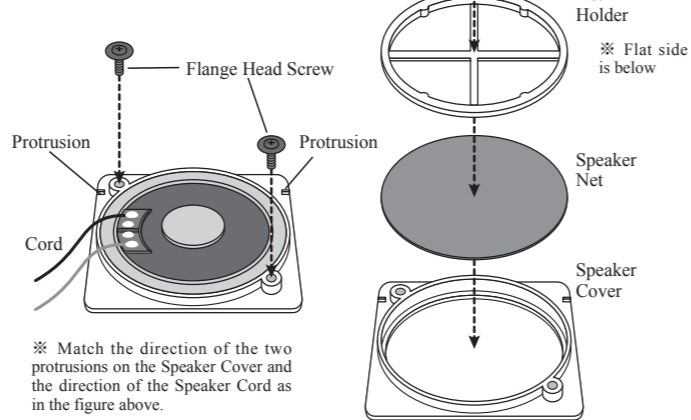

※ Match the direction of the two protrusions on the Speaker Cover and the direction of the Speaker Cord as in the figure above.

8 Assemble the PCB.

① Connect the Record Needle, the Motor, and the Speaker to the corresponding connectors on the PCB.

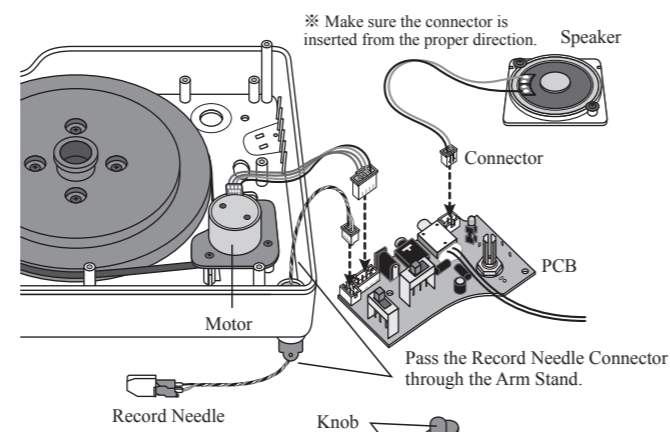

② Place the knobs on the switches of the PCB.

※ Note the vertical and horizontal orientation of the Knob.

③ Adjust the position of the PCB so that the Knob, the LED, and the Volume come out of the holes inside the Main Unit (top).

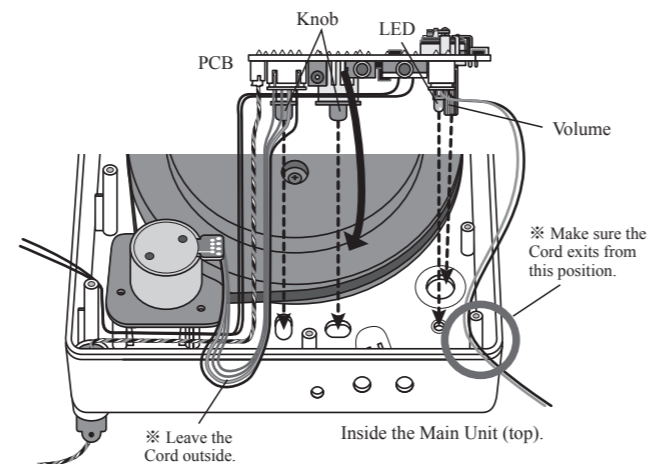

※ Leave the Cord outside.

④ Push the PBC from above until it clicks.

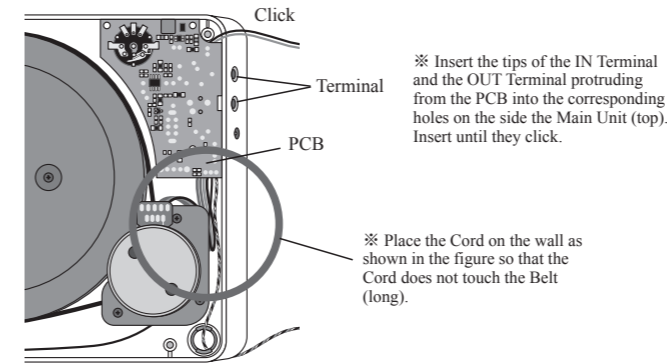

※ Insert the tips of the IN Terminal and the OUT Terminal protruding from the PCB into the corresponding holes on the side of the Main Unit (top). Insert until they click.

※ Place the Cord on the wall as shown in the figure so that the Cord does not touch the Belt (long).

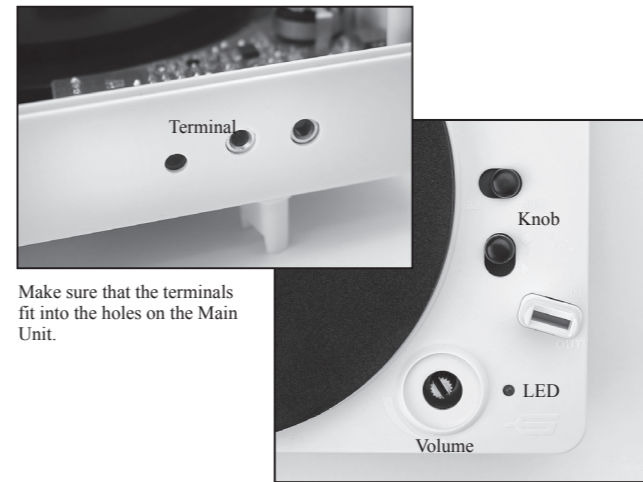

Make sure that the terminals fit into the holes on the Main Unit.

Make sure that the Knob, the LED, and the Volume come out correctly.

⑤ Install the PCB on the Main Unit (top) using the 3 Pan Head Screws. Insert the black Cord protruding from the PCB into the gap between the 2 white protrusions and then fasten it with the Flange Head Screw to prevent it from coming off.

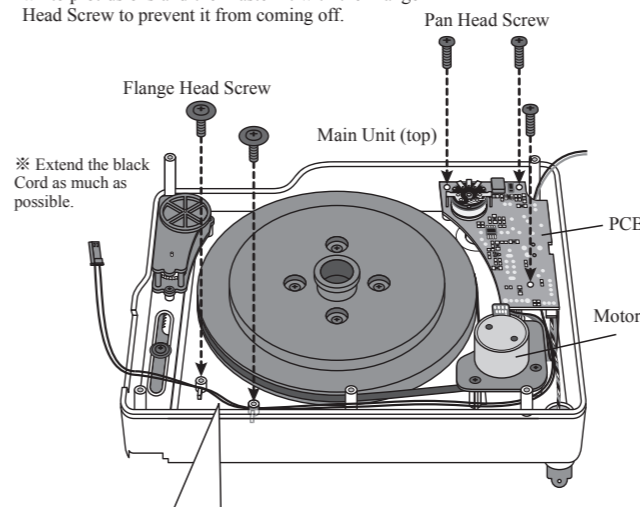

※ Extend the black Cord as much as possible.

Make sure that the black Cord wiring is correct.

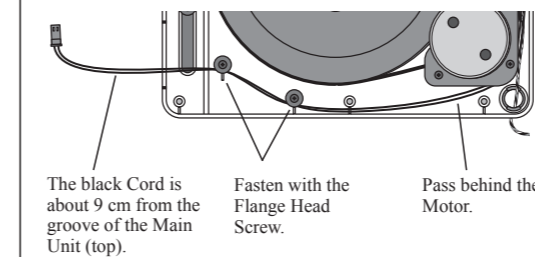

The black Cord is about 9 cm from the groove of the Main Unit (top).

Fasten with the Flange Head Screw.

Pass behind the Motor.

9 Install the Speaker.

① Insert the Speaker Cover into the groove of the Main Unit (bottom).

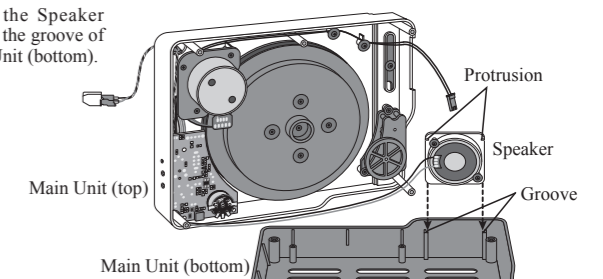

② Insert the Speaker Cord into the gap between the 2 black protrusions on the inside of the Main Unit (bottom) and then fasten it with the Flange Head Screw so that it does not come off.

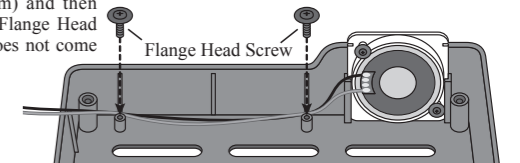

10 Hang the Belt (short).

Place the Belt (short) around the Pulley Gear and the Turntable.

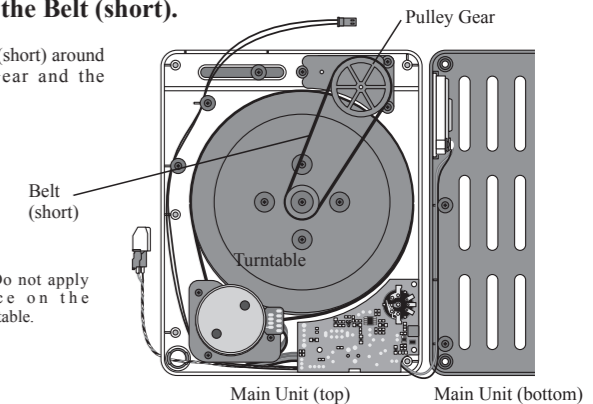

※ Do not apply force on the Turntable.

11 Assemble the Main Unit and attach the Volume Control Knob.

Place the Main Unit (top) onto the Main Unit (bottom), but do not set the screws yet. Insert the Volume Control Knob into the tip of the Volume which can be seen from the hole of the Main Unit in the following order.

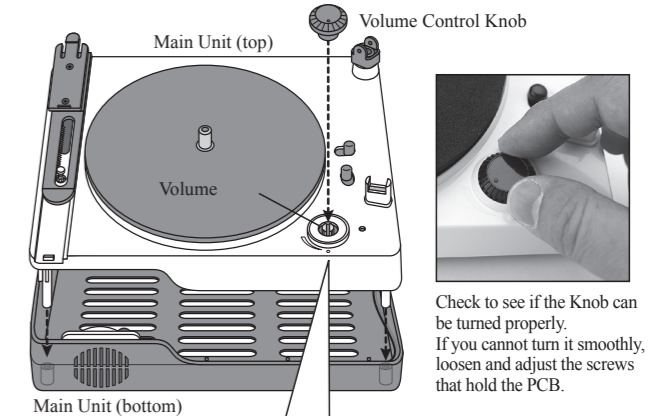

Check to see if the Knob can be turned properly. If you cannot turn it smoothly, loosen and adjust the screws that hold the PCB.

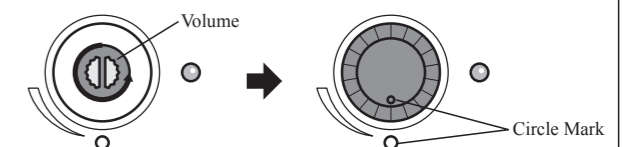

① Insert the Volume Control Knob by a little and then turn the Volume all the way to the left.

② At the position where the Circle Mark is met (slightly off due to the notch), insert the Volume Control Knob all the way down.

Assemble the Tonarm

1 Attach the Record Needle to the Tonarm.

① Remove the Cover attached to the Record Needle.

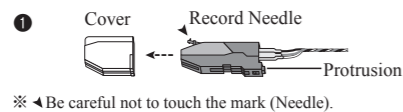

※ Be careful not to touch the mark (Needle).

② Insert the protrusion of the Record Needle into the dent inside the tip of the Tonarm (A). Then push the other side into the claw part until it clicks (B).

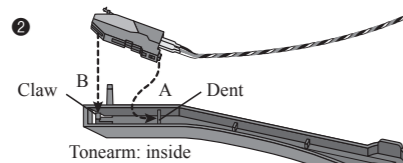

③ Push the Cord of the Record Needle into the groove.

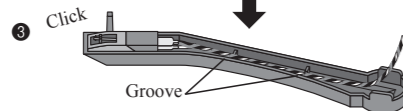

2 Attach the Tonarm to the Main Unit.

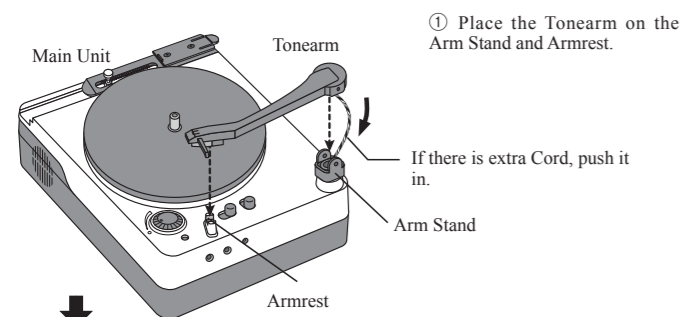

① Place the Tonarm on the Arm Stand and Armrest.

If there is extra Cord, push it in.

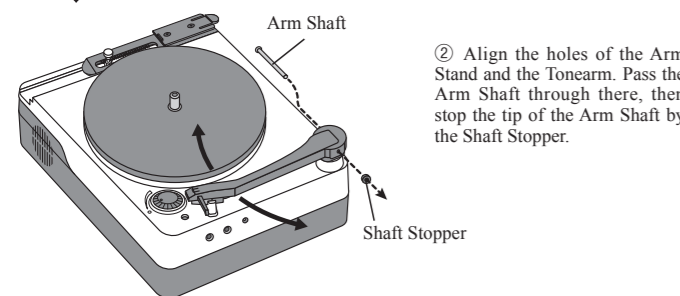

② Align the holes of the Arm Stand and the Tonarm. Pass the Arm Shaft through there, then stop the tip of the Arm Shaft by the Shaft Stopper.

※ Move the Tonarm widely left and right to make sure it does not get stuck.

2 Attach the Needle Pressure Adjusting Device to the Cutter Head.

Align the 2 screw holes and then fasten the Needle Pressure Adjusting Device to the Cutter Head with the Flathead screws.

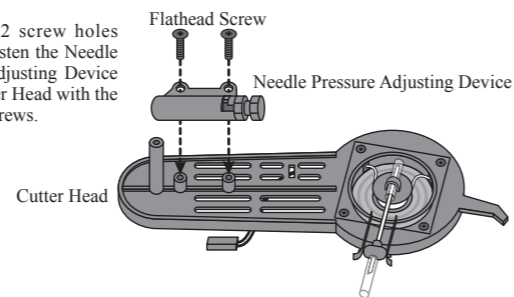

3 Attach the Cutter Head to the Main Unit.

① Position the Cutter Head and the Cutter Stand so that the holes are aligned. Then, pass the Cutter Shaft through.

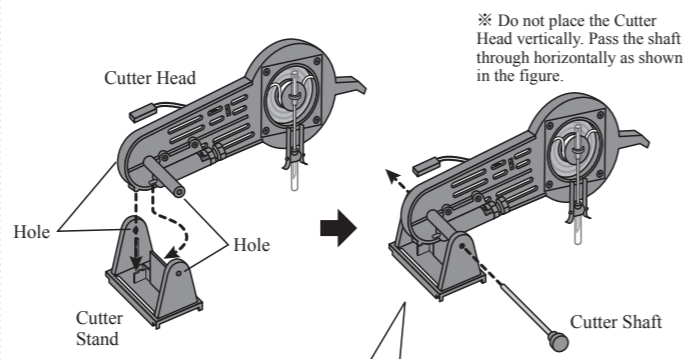

※ Do not place the Cutter Head vertically. Pass the shaft through horizontally as shown in the figure.

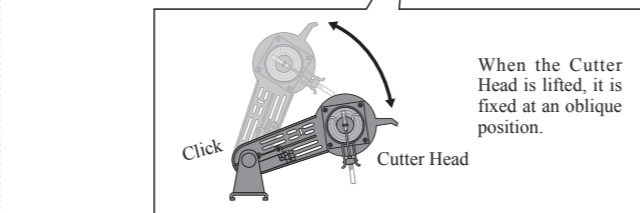

When the Cutter Head is lifted, it is fixed at an oblique position.

② While pushing down the claw at the end of the Slide using the bottom of the Cutter Stand, slide the Cutter Stand through the grooves of the Slide. When removing the Cutter Stand, remove it while pushing down the claw.

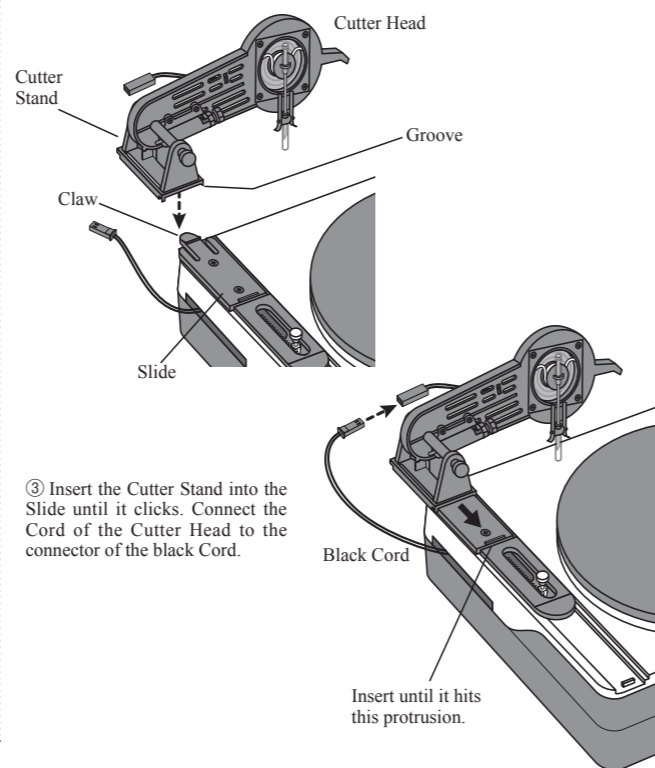

③ Insert the Cutter Stand into the Slide until it clicks. Connect the Cord of the Cutter Head to the connector of the black Cord.

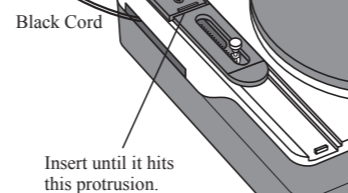

Insert until it hits this protrusion.

4 Check the operation of the Turntable.

Connect the Power Supply Terminal of the Main Unit to the Power Supply through the USB Power Cable. Then, check the operation of ①~②. If it does not work, remove the Main Unit (bottom). Then, make sure the Belt (long) and (short) have been attached properly and are not twisted, and that the connectors have been correctly inserted into the PCB.

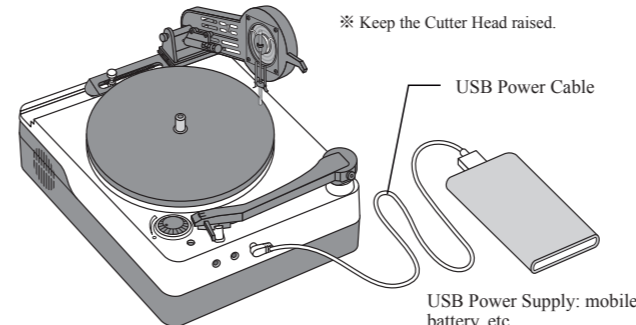

※ Keep the Cutter Head raised.

USB Power Cable

USB Power Supply: mobile battery, etc.

1

When the Volume Switch is turned clockwise, the LED turns on and the Turntable rotates. Change the Rotation Speed Switch and check that the rotation speed changes between 45 and 33.

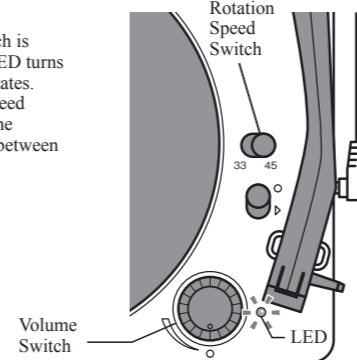

2

Make sure that the Pulley Gear (white) that protrudes from the Slide is rotating slowly.

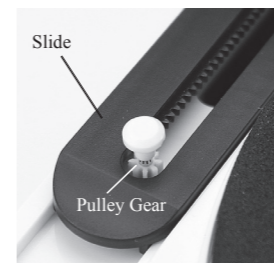

5 After confirming the operation, attach the Main Unit (bottom).

Set the Main Unit with 5 Pan Head Screws, and attach a Sponge Seal to each screw hole.

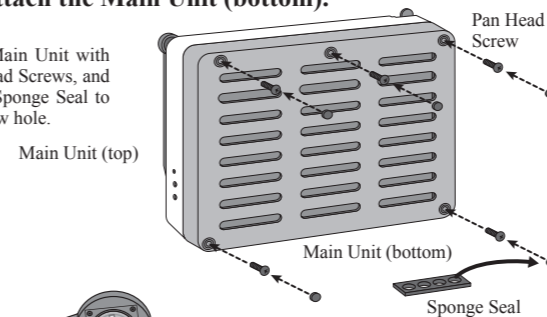

Main Unit (top)

Main Unit (bottom)

Sponge Seal

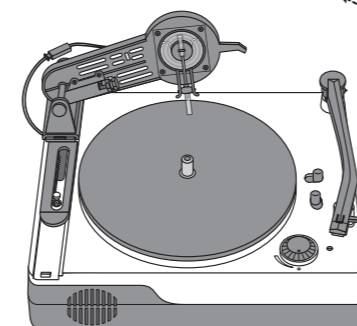

It's done!

Let's try cutting (recording) a record!

1 Connect the Power Supply and the sound source to the Main Unit.

Connect a sound source to the Input Terminal (IN) using a 3.5mm audio cable. Since this input is monoaural, connect the monoaural end of the cable to the Main Unit and the stereo end of the cable to the sound source device.

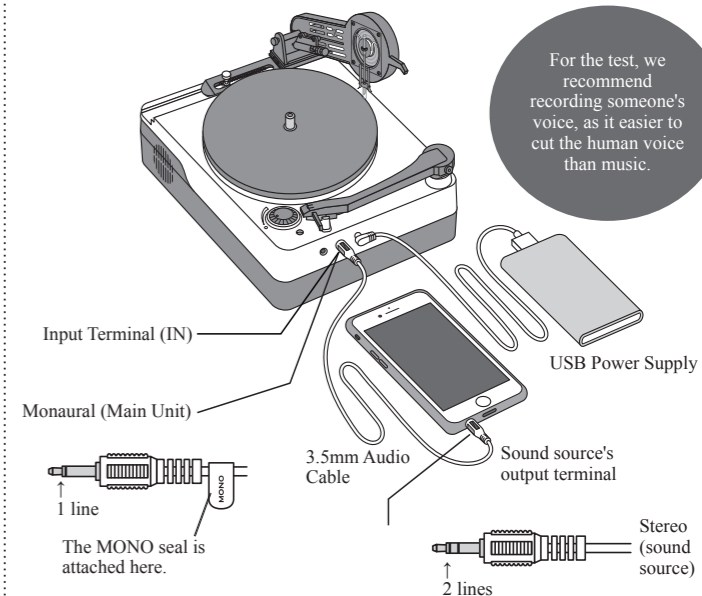

For the test, we recommend recording someone's voice, as it is easier to cut the human voice than music.

2 Prepare the Cutter Head.

① With the Cutter Head lifted, turn the Needle Pressure Adjusting Device counterclockwise so that the distance between A and B is about 1 cm.

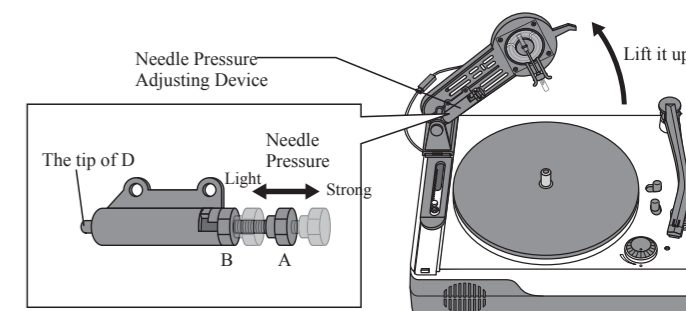

You can change the needle pressure of the Needle Pressure Adjusting Device by adjusting the strength of the Spring.

② Move the Cutter Head to the end while pressing down the head of the Pulley Gear protruding from the Slide.

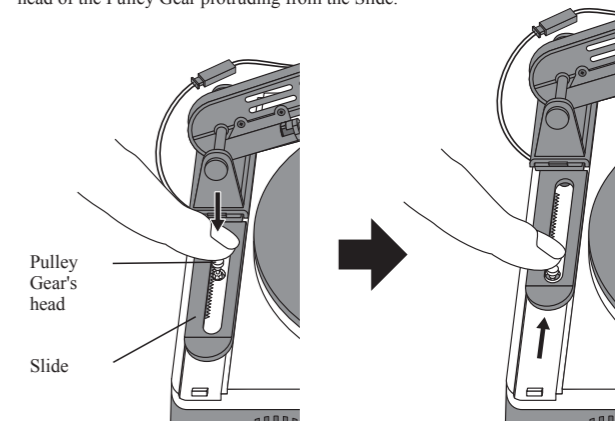

You can release the Slide's gear (black) by pressing the head of the Pulley Gear (white).

Move the Cutter Head to the end.

Assemble the Cutter Head

1 Assemble the Needle Pressure Adjusting Device.

Align the Spring to Part A ~ E of the Needle Pressure Adjusting Device.

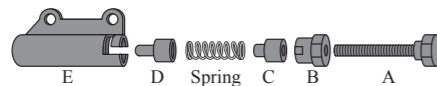

Turn A through B in clockwise direction. Press the tip of A into the hole of C firmly. Insert one end of the Spring through the protrusion of C, and insert the other end of the Spring into the hole of D.

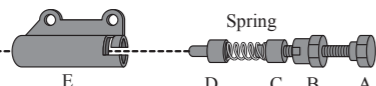

Put everything through E, rotate the protrusion of B and then stop.

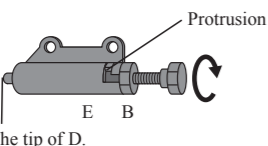

The completion of the Needle Pressure Adjusting Device.

3 Set the Record.

Place the Record on the Turntable and turn the Record Holder counterclockwise to hold the Record.

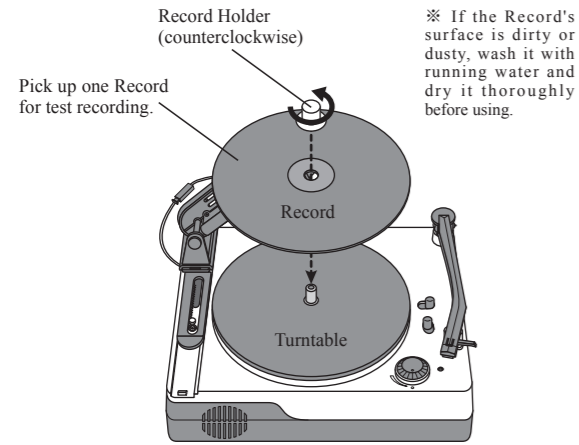

4 Set the Switch and the Volume Knob.

Set the Recording / Playback Switch to "o (Recording)" and the Rotation Speed Switch to "45 (right side)". When the Volume Switch is turned ON, the LED lights on and the Turntable rotates. Turn the Volume Knob to about 90°.

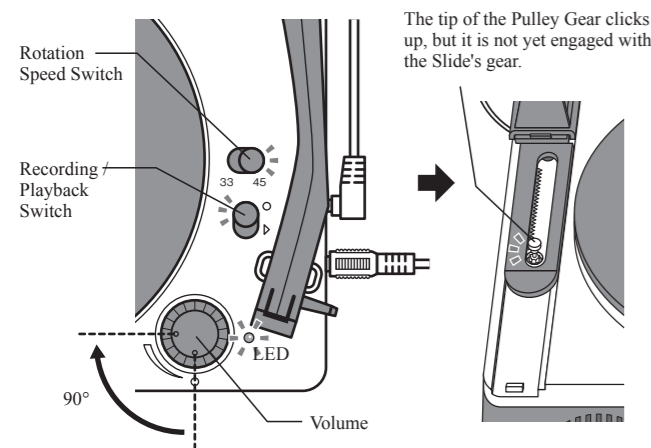

5 Play the sound source at the maximum volume and make sure that the sound is coming out from the Cutter Head.

If the sound is cracked or the Cutter Head is shaking, slightly lower the Volume of the Main Unit.

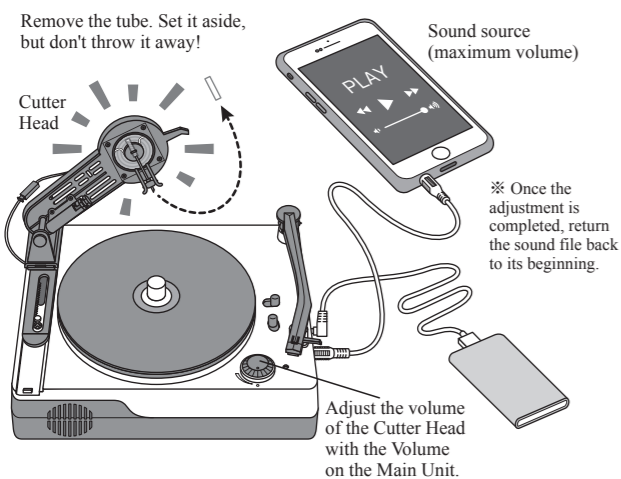

6 Start moving the Cutter Head.

Push the Cutter Stand slightly forward, and make sure that the gear is engaged and the Cutter Head slowly starts to move in your direction (front side).

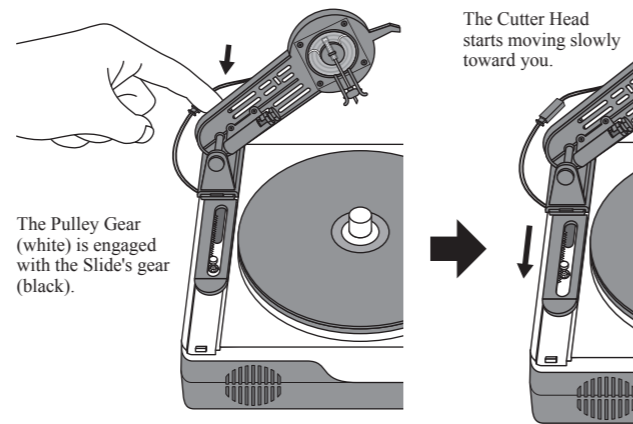

7 Lower the Cutter Head to play the sound source. Then, perform a test cutting for about 10 seconds.

① After lowering the Cutter Head gently and putting the Needle on the Record, play the sound source. The groove of the sound is being cut.

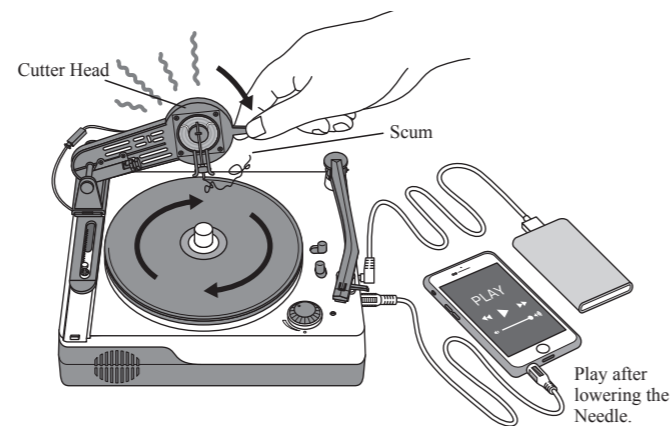

② Since this is a test cutting, after recording for about 10 seconds, raise the Cutter Head and turn off the power. Then, stop the sound source. This ends the test cutting.

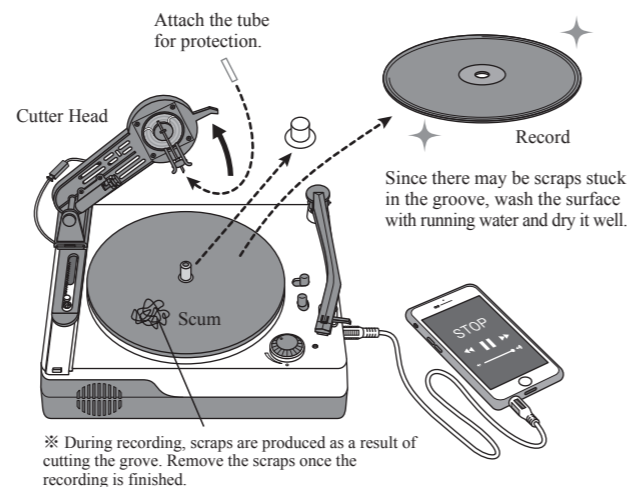

Let's play what was recorded!

1 Set the Switch and the Volume Knob.

Set the Recording / Playback Switch to "▷ (Playback)". Make sure that the Rotation Speed Switch is set to "45". Turn the Power on and turn down the Volume.

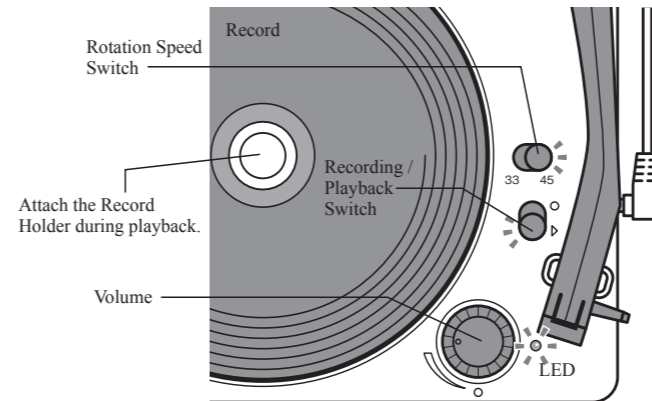

2 Raise the Tonearm and gently place the Record Needle.

Place the Record Needle in the outermost groove. As you raise the Volume, the recorded sound comes out from the Speaker.

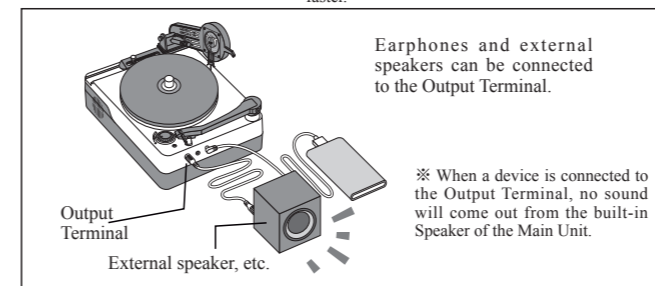
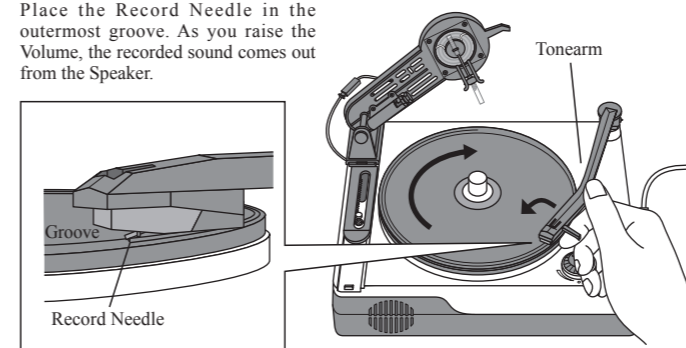

3 When playback is finished.

Return the Tonearm to the Armrest and turn off the power.

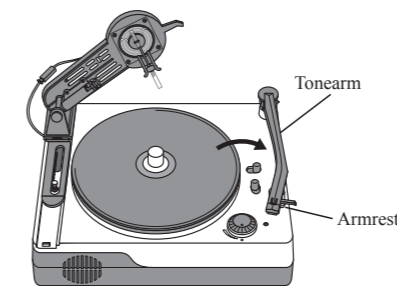

How to adjust

During the playback, if the noise is loud and the sound is low, or the needle jumps, refer to the next page. Adjust the sound source's volume and the needle pressure and then repeat the test cutting using a different location of the same disk.

A convenient Time Counter that can show the recordable area.

If you put the Time Counter on the Record, you can see the starting and the ending positions of the cutting on the Record and the approximate recording time for each rotation speed.

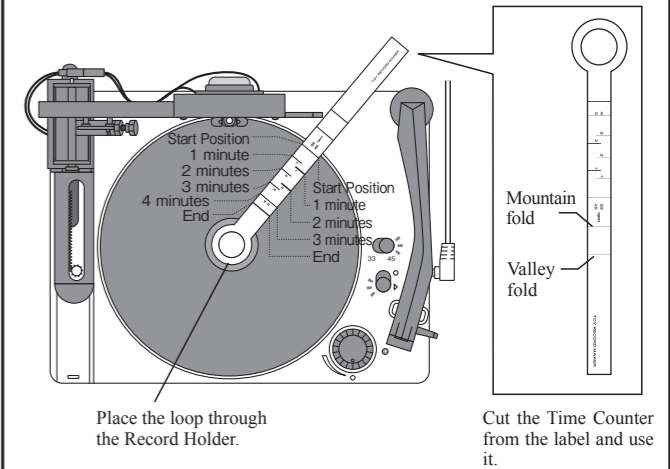

Let's make a record jacket.

Cut out the jacket from the jacket paper with a cutter and fold it in the middle. Then, fold and glue the left and the right sticking margins to complete the jacket.

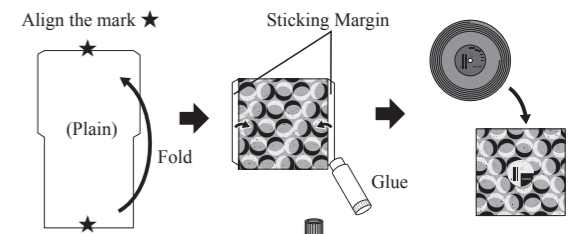

Label the Record

Put the Record on the Turntable. You can paste the label neatly by using the axis.

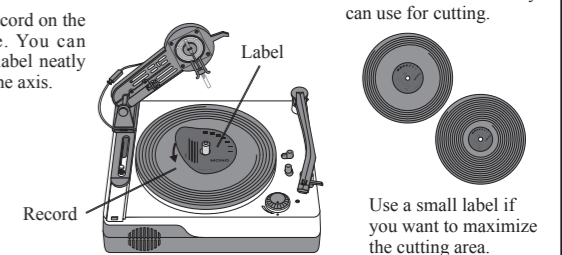

Let's listen to a commercial EP Record!

After moving the Cutter Head all the way back, push the claw of the Slide further down so that the Cutter Head protrudes about halfway out from the Main Unit. For a donut record, set the EP Adapter after placing it on the axis.

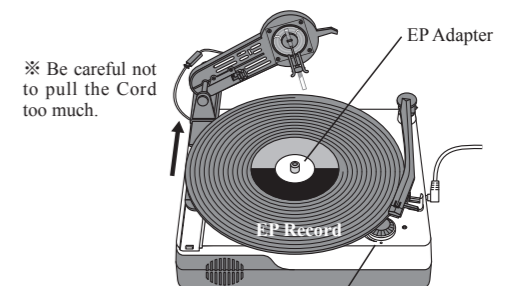

How to adjust the recording level on the next page.

How to adjust the recording level

In order to cut it properly, it is necessary to adjust the needle pressure and the Volume according to the sound source. You may not be able to record well at first, but repeat the test recording and playback while changing the needle pressure and the volume condition little by little to find the optimal balance.

Tip

The basic setting is to adjust the **Volume of the Main Unit to 90 degrees (at 9 o'clock position)**. Then, set the **needle pressure to a position where the screw is about halfway out**.

Perform a test playback. You can **raise the Volume if the needle is not skipping**.

Try to aim for the maximum volume without having the needle skip.

Since the most influential factor in cutting is the state of the Cutting Needle, **repeat the test in the shortest amount of time possible in order to not wear the needle out**.

To adjust the needle pressure and the volume, refer to the graphs below.

Relationship between the worn state of Cutting Needle and Needle Pressure

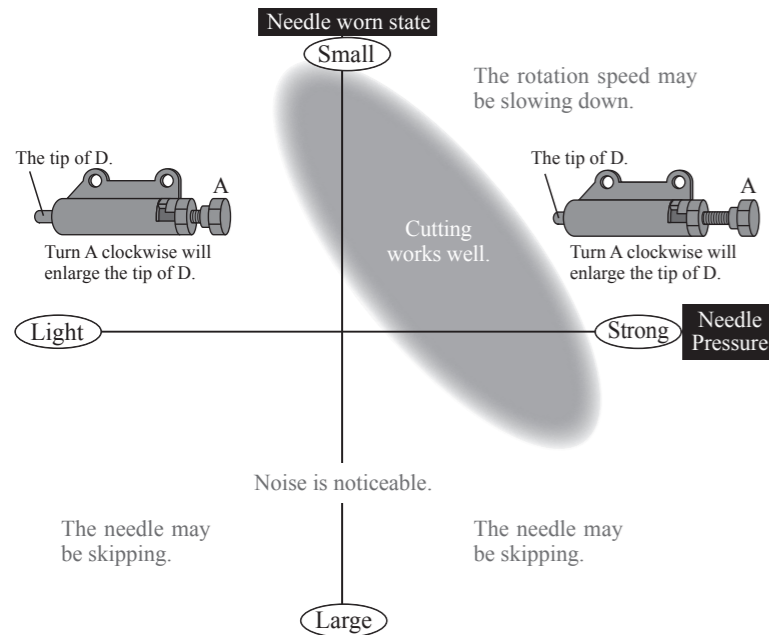

Relationship between the worn state of Cutting Needle and the volume

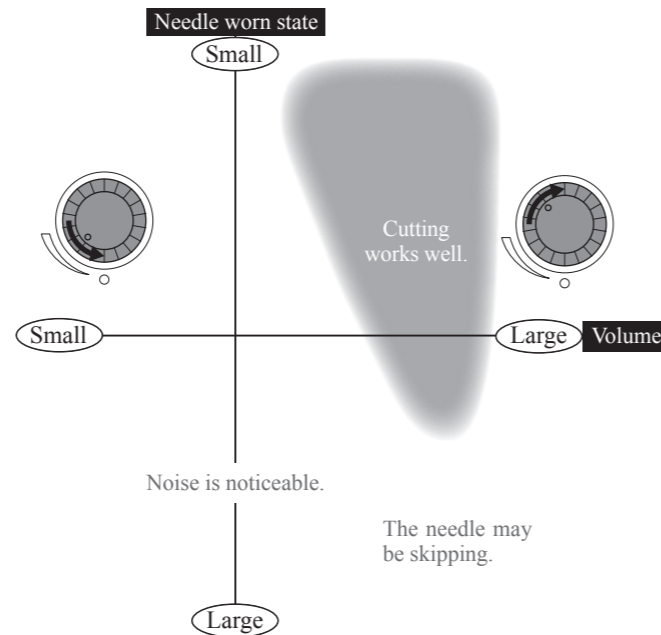

Method to reduce needle jumping

Depending on the sound source, the needle may skip even with the above adjustment.

In that case, **using an equalizer may improve the situation**.

Read the article on page 12 and try again.



For the test cutting, try recording several recordings of about 10 seconds each, on one disk.

Push the tip of the Pulley Gear coming out of the Slide. Move the Cutter Head and then start recording on areas where a groove has not been cut yet.

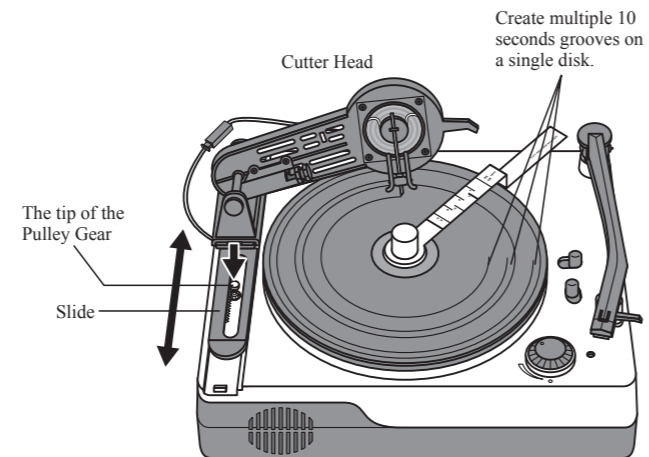

※ As the tip of the Pulley Gear reaches to the end, remove the needle so that it will not continue looping the same groove and damage the Record. Carefully check the time counter for the recording time.

What if the Cutting Needle is worn? How to check and replace the Needle.

Change the Cutting Needle

The blade of the Cutting Needle wears out after recording many times, causing the recorded sound to be noisy. Replace with a new needle if you are concerned about the noise.

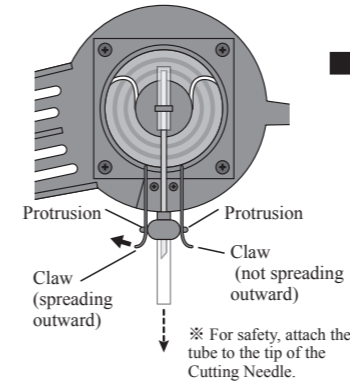

To remove the needle, spread the left claw and turn the needle to remove the protrusion. Then, pull the needle down.

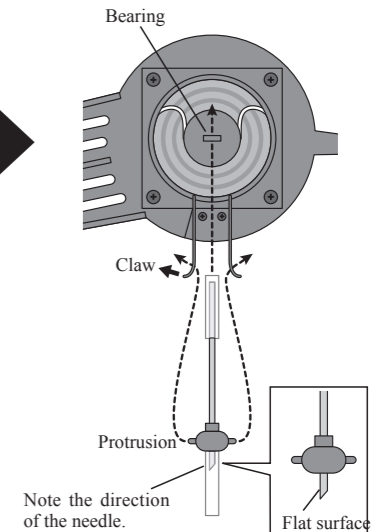
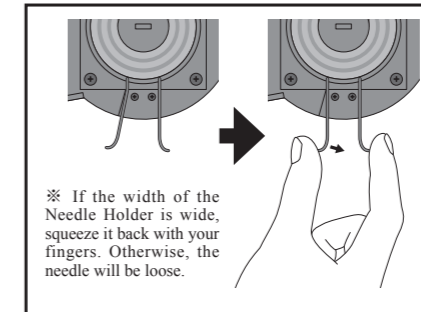

To attach a new needle, slide the tube at the end of the needle through the bearing in the middle of the Cutter Head while spreading the claws to engage the protrusion.

Check here after setting the Cutting Needle!

If the Cutting Needle is not set correctly, the vibration of the sound can not be transmitted properly and the movement of the needle will be weakened. Also the noise will increase due to the needle trembling.

1 Is the needle centered?

Move the needle with your finger so that it is in the center.

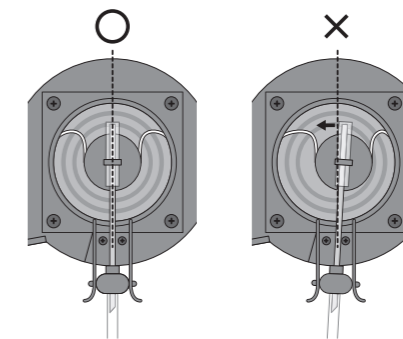

2 Is the bearing position of the Cutter Head correct?

When the bearing of the Cutter Head is exactly in the middle of the square frame, it transmits the vibrations to the needle neatly. If the position of the bearing is shifted up or down, adjust it back to the middle.

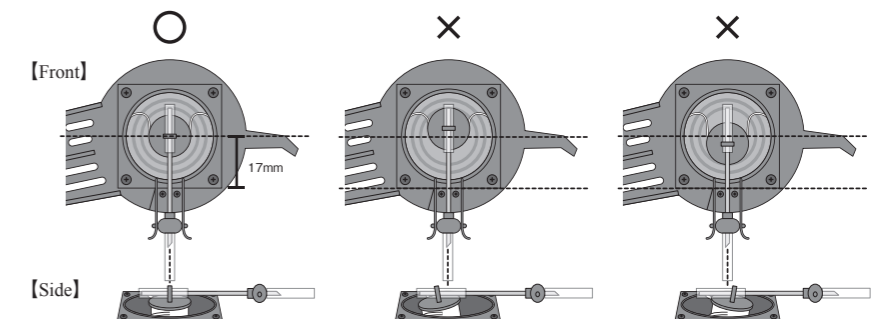



Q : I have trouble cutting.

A : ① Refer to the figure on the right to make sure that the assembly and the setting are correct.

② The Cutting Needle may be worn. Replace the needle and try again (P23).

③ Check to see if the cutting needle is mounted in the correct direction (P23).

④ If the Record is dirty or covered with dust, wash it off with running water or diluted neutral detergent and dry it thoroughly before using.

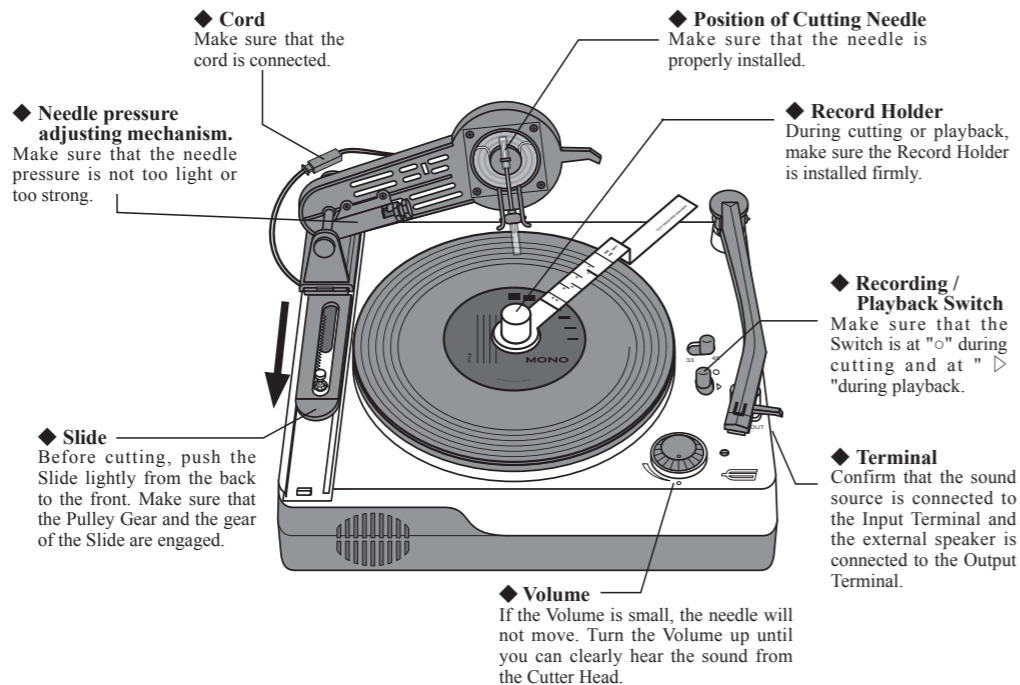

Q : The sound coming from the Cutter Head is trembling.

A : If the Needle Holder is wide, the noise may be heard. See page 69 on how to narrow the width of the Needle Holder.

Also, if there is a gap between the bearing of the Cutter Head and the Tube of the Needle, the vibration can not be transmitted properly to the needle and the sound will be trembling. In this case, wrap a small tape around the Needle as shown below to fill the gap.

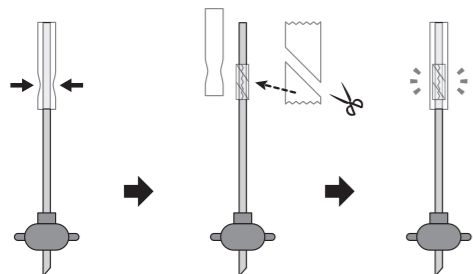

The Tube may become thinner after vibration.

Remove the Tube, cut the tape into small piece and wrap it around the Needle.

When the tube is inserted back to the Needle, it becomes slightly thicker. So, the gap between the bearing and the Cutter Head is filled.

Q : The scraps from the cutting hinders the movement of the Cutting Needle.

A : If scraps accumulate, they may get under the Needle or get stuck in the Record Holder, causing the Needle to jump or creating noise. In that case, please blow the scraps off the disk during the cutting with your breath or with a dryer.

Q : The Needle is skipping.

A : If the volume level of the sound source is too high, the vibration of the Needle may be too high and the sound may not be inputted properly. Read the article from Page 12 and Page 22 to try out an equalizer.

Q : I can not record a high volume level of sound and the noise is big.

A : If the volume level of the sound source is low or the output of the device is weak, sound may not be inputted properly. Read the article from page 12 and try out a preamplifier or an equalizer application.

● **Plastic materials used in this kit**

Needle Pressure Adjusting Device A ~ E, Arm Stand, Washer, Shaft Stopper (black): POM
Mat, Sponge Seal: EVA, Belt long/short: synthetic rubber, blank record: PS, Other parts: ABS

● **Metal materials used in this kit**

Arm Shaft, Cutter Shaft, Spring (nickel plating): iron, Screws: iron, Cutting Needle: alloy

※ When no longer needed, please dispose the device according to the rules and regulations of each local government.

Gakken

大人の科学
マガジン

YURI SUZUKI